

TS4-A-O

PV Module Advanced Add-On

The TS4-A-O (Optimization) is the advanced add-on optimization solution that brings smart module functionality to standard PV modules for higher reliability.

Improve energy efficiency by upgrading underperforming PV systems or adding smart features to new installations.

TS4-A-O supports PV modules up to 700Wp.

Features:

- Module-level **optimization** for increased energy yield and greater design flexibility;
- Automatic or manual **shutdown**;
- Module-level **monitoring** for energy production tracking and system management;
- **Easy installation**, attachable to the module frame or mounting system;
- **Smart Commissioning**, configuration and commissioning achievable from Android/iOS device.

Dimensions:

Width: 138.4 mm

Height: 22.9 mm

Depth: 139.7 mm

Weight: 520 g



Model	TS4-A-0
TECHNICAL DATA	
Energy Product code	90900700
Max. Power [W]	700
Max. Input Voltage (Vac at the lowest temperature) [V]	80
Voltage Range [V]	16 ~ 80
Max. Current [A]	15
Recommended Fuse rating [A]	30
GENERAL DATA	
Dimensions [WxHxD] [mm]	138.4x22.9x139.7
Weight [g]	520
Operating Temperature range [°C]	-40 ~70 (-40°F~158°F)
Protection degree	IP68
Altitude [m]	2000
Output cable Length [m]	1.2 (standard)
Connectors	MC4, EV02
Communication	Wireless
Standard	CE, TÜV
Warranty [years]	2

N.B: For monitoring and security functions you must purchase the Kit Cloud Connect Tigo (COD. 90900720) complete with datalogger, Access Point (TPA) and DIN mounted power supply.

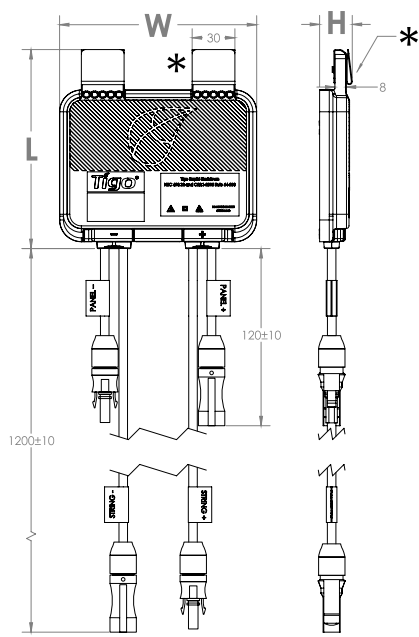

* Removable clips for mounting

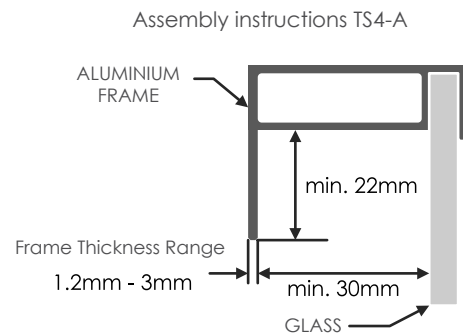

KIT COMPOSITION

Cloud Connect Advanced (CCA)

Compact Datalogger

The Cloud Connect Advanced (CCA) is a compact, powerful data logger and the communication hub of the Tigo SMART platform. It powers the monitoring and safety capabilities of Tigo smart modules.

Features:

- Collect data from up to 900 TS4 units;
- Supports wired and wireless networks;
- Control monitoring and safety features;
- Configure and commission with Tigo SMART App;
- Monitor 3rd party devices via Modbus (inverters, charge controllers, weather stations, and revenue grade meters...);
- Control the rapid shutdown function.



Model	CCA	POWER SUPPLY
TECHNICAL DATA		
Energy Product code	Complete kit: 90900720	
Input Voltage [V]	10 ~ 25 Vdc	100 ~ 240 Vac
Power Consumption [W]	3 ~ 7	-
CCA Capacity	Each CCA supports up to 900 TS4 units and up to 7 TAPs	
GENERAL DATA		
Dimensions [WxHxD] [mm]	31x71.54x115.51 (CCA only)	-
Weight [g]	126 (CCA only)	-
Operating Temperature range [°C]	-20°C~70°C (-4°F~158°F) (CCA only)	
Protection degree	IP68, Type 4R (if installed in outdoor boxes)	-
Cooling	Natural Convection	
Led Status	Multi-function LED status indicator	
Communication	Mobile App: Tigo SMART App for Android and iOS	
Standard	CE, FCC, CSAus	
Warranty [years]	2	

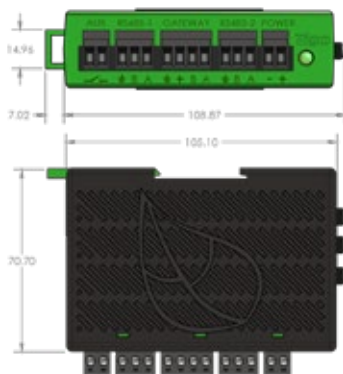

Tigo Access Point (TPA)

Features:

- Collect data from up to 300 TS4 units;
- Wireless MESH communication;
- High definition sampling rate;
- Scalable architecture;
- Mounts easily on module frame without tools.

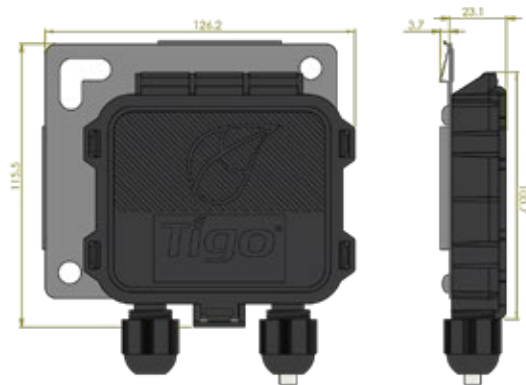

Model	TPA
TECHNICAL DATA	
Energy Product code	90900730
TPA Capacity	Each TAP supports up to 300 TS4 units up to 115ft (35m) away
GENERAL DATA	
Dimensions [WxHxD] [mm]	126.2x26.8x130 (with bracket)
Weight [g]	227
Operating Temperature range [°C]	-20°C~+85°C (-4°F~185°F)
Protection degree	IP68, Type 4R
Standard	CE, FCC, CSAus
Warranty [years]	2

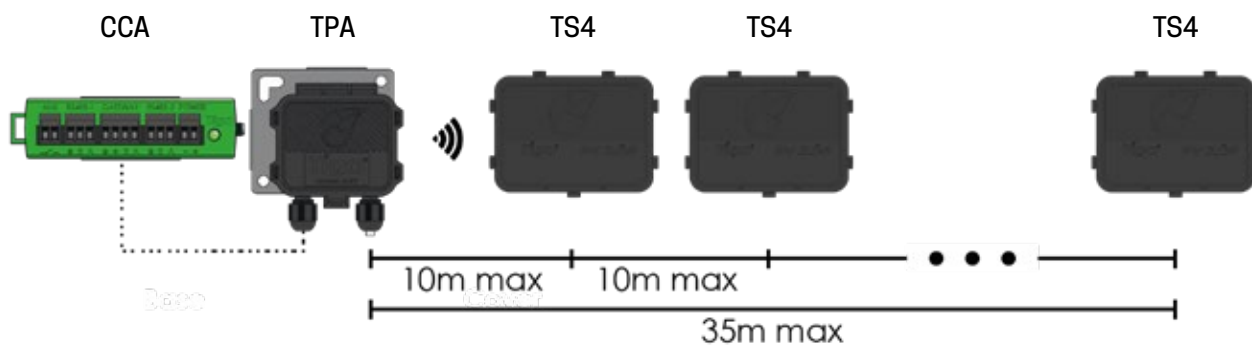

Product Code **Kit Cloud Connect Tigo** (CCA+TPA+DIN): **90900720**

Energy S.p.A.

Registered office:
Piazza Manifattura, 1
38068, Rovereto TN
Tel. +39 0464 350812 - Fax +39 0464 350512



www.energyspa.com
www.bandoaccumulo.com

Energy S.p.A.I

Operation/Warehouse:
Via Zona Industriale, 10
35020, Sant'Angelo di Piove di Sacco (PD)
info@energysynt.com
Tel. +39 049 2701296 - Fax +39 049 8599098